

SITE STATISTICS

PARCEL (PIDs): 224745
 CURRENT ZONING: M-1 (MANUFACTURING AND INDUSTRIAL DISTRICT)
 PROPOSED ZONING: R-8 (RESIDENTIAL DISTRICT - SPECIAL USE)
 PROPOSED USE: RESIDENTIAL (TOWNHOUSES)
 TOTAL SITE AREA: 53.21 ACRES
 AREA TO BE DONATED TO TOWN: 15.47 ACRES
 AREA TO BE RETAINED: 37.74 ACRES
 STREAM WATERSHED: DUTCHMAN'S CREEK
 FEMA (FIRM): NO PORTIONS OF THIS PROPERTY ARE LOCATED IN A FLOOD ZONE AS DEFINED BY FEMA FIRM MAP NO. 3710357900J, DATED SEPTEMBER 28, 2007
 PROPOSED NUMBER OF UNITS: 150

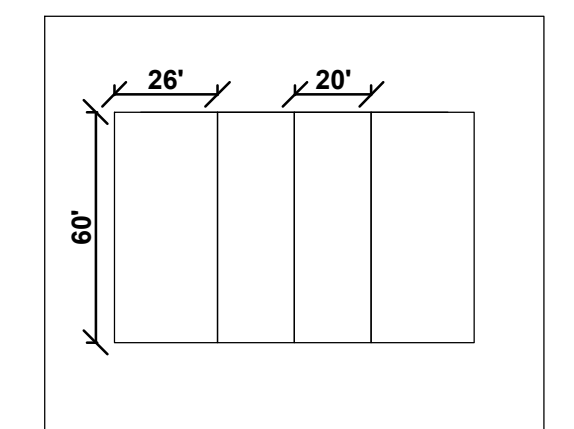

TYPICAL TOWNHOUSE PAD DIMENSIONS



TYPICAL TOWNHOUSE BUILDING ELEVATION

REV. NO.	DESCRIPTIONS	DATE

8020 Tower Point Drive
 Charlotte, North Carolina 28227
 Phone: (704) 841-2588, Fax: (704) 841-2567
 NC License# F-1222
 www.mckimcreed.com

AUTUMN BROOK SUBDIVISION
MARIPOSA ROAD
STANLEY, NC

SKETCH PLAN

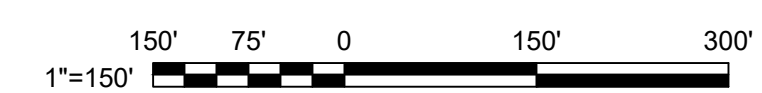

DATE: MAY 2021	SCALE	1 DRAWING NUMBER REVISION
MCE PROJ. # 07780-0009	HORIZONTAL: 1" = 150'	
DRAWN JCB	VERTICAL: N/A	
DESIGNED JCB		
CHECKED KJC		
PROJ. MGR. KJC		
STATUS: SKETCH PLAN		
		NOT FOR CONSTRUCTION